

Installation Guide

Atmospherix AS and Atmospherix A20

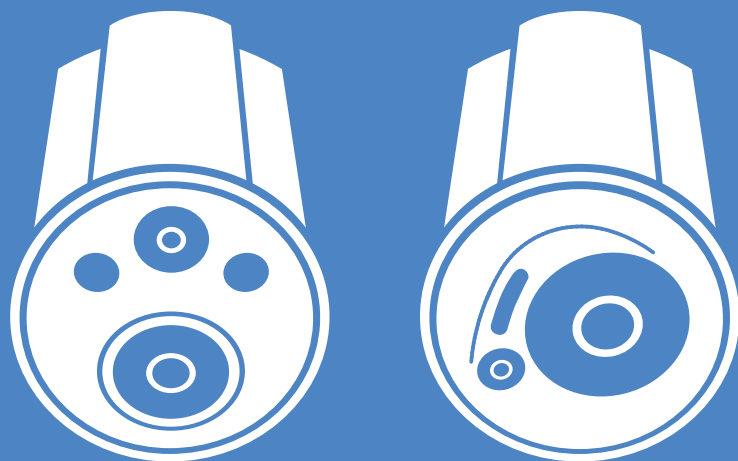

Congratulations on choosing Krix

Your Krix speakers are designed to reproduce the highest quality sound. To get the best performance from your speakers please read these installation instructions thoroughly as there are many factors that influence the performance of your speakers. If you have any difficulties please contact one of our friendly authorised Krix dealers.

setup in brief

The following setup procedure will help you achieve the best performance from your inceiling speaker:

1. unpacking

Remove your speaker from the packaging

2. introduction

Learn about the Atmospherix AS and Atmospherix A20

3. before you begin

Determine a suitable location for your speakers

4. installation

Cut mounting hole, connect cabling and install speaker

5. listen and enjoy

Listen to your favourite music/movies and enjoy

disclaimer

Drilling into anything can be dangerous. You should make sure you know what is behind or inside the surface that you are drilling before you start to drill. For example, you might strike an electrical cable.

You must install the speaker securely to the surface that you are fixing it to. If you don't, injury or damage may occur.

If you do not feel entirely confident about installing this product, contact a professional installer.

Disclaimer

To the extent permissible by law:

All warranties, conditions, representations, promises and statements relating howsoever to this product whether express or implied and whether in contract or tort are excluded to the extent permitted by law; and

Our liability to you under a condition or warranty (if any) implied into this sale and purchase agreement relating to these brackets by the Trade Practices Act 1974 (as amended) or any other law (whether a law of Australia or any other country) other than a condition implied by Section 69 of the said Act is limited at our option to:

the replacement of the product; or
the supply of an equivalent product; or
the repair of the product.

If you do not accept the above conditions, return this product (in the original packaging) with proof of purchase for a full refund.

introduction

introduction

The Atmospherix AS and Atmospherix A20 are high quality in-ceiling loudspeakers featuring fully sealed back-boxes to control and maximise bass response, whilst keeping out dust and other ceiling inhabitants.

The Atmospherix A20 employs an acoustically optimised front baffle angled at 20 degrees allowing its sound output to be projected towards your primary listening area. The standard Atmospherix employs a flat front baffle for uniform sound coverage in all directions. (figure 1)

applications best suited to Atmospherix AS

The wide uniform coverage of the Atmospherix AS makes it the ideal choice for 2 channel stereo and background music applications. Its uniform coverage is ideally suited to any applications where the listening area is not confined to a specific part of the room. For examples, hallways, dining rooms, office spaces and bedrooms and multipurpose rooms. (figure 2)

applications suited to Atmospherix A20

The ability of the Atmospherix A20 to project sound toward your listening primary listening area makes it ideally suited to home cinema applications (figure 3). Dialogue will become more articulate, music will have better definition and surround effects will become more involving and realistic. The A20's ability to direct more sound towards the listener results in less sound reflecting off walls and other surfaces in the room creating a clearer, more three dimensional soundstage. The A20 may also be useful for background music applications where the speakers must be placed near a side wall for aesthetic or structural reasons. In this application the A20 can be used to project the sound towards the centre of the room.

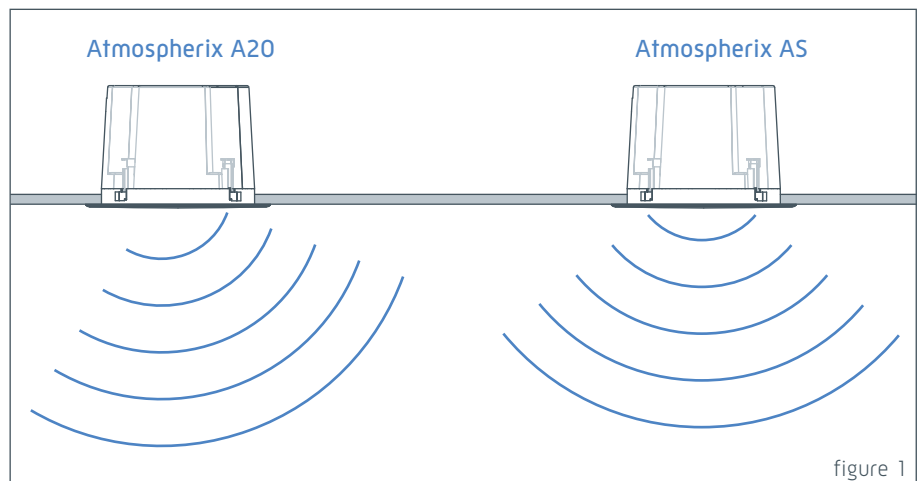

figure 1

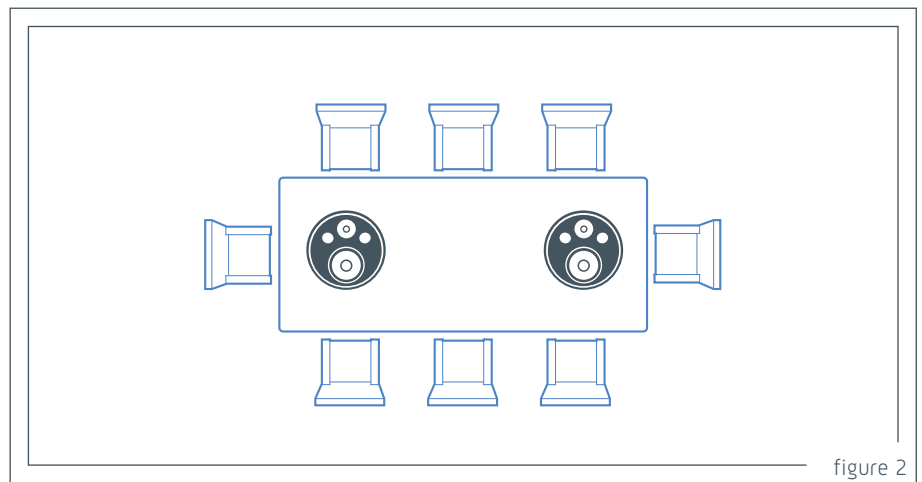

figure 2

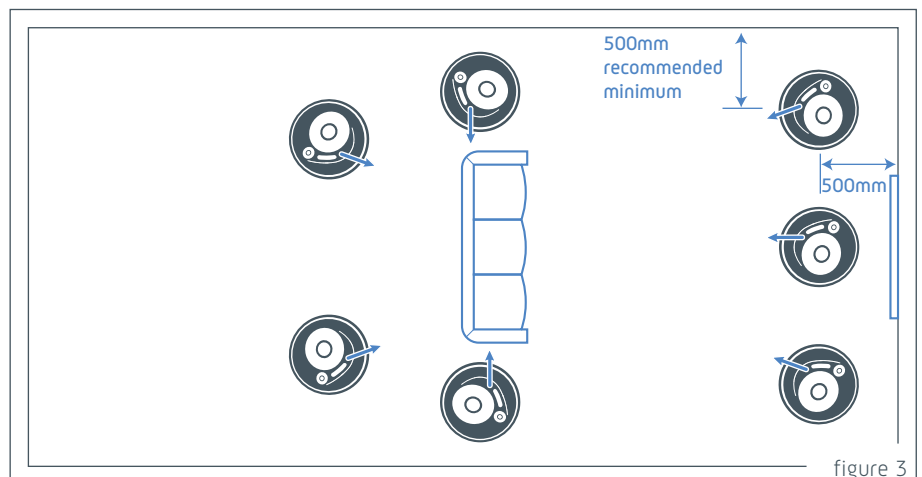

figure 3

installation

before you begin

⚠ Please read the disclaimer on page 2 of this manual.

- Refers to page 3 of this manual and discuss with your local Krix distributor, or installation consultant, to determine the best location for your loudspeakers. Be sure to check for any obstructions, such as electrical wiring, plumbing, stud work or air conditioning ducts before commencing the installation. (figure 4)

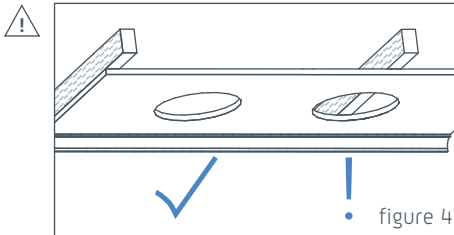

- Also ensure that there is enough ceiling/wall space to accommodate the speaker enclosure.

connecting

To ensure optimum performance it is important that your speaker system is connected properly:

⚠ Turn off all electronic equipment and disconnect from the power point.

- Follow the connection instructions supplied with your amplifier, CD/DVD, hard disk recorder, video player etc.
- Install speaker cable in wall or ceiling cavity, or run cable along wall surface. Allow approximately 300mm of excess cable to facilitate loudspeaker installation.
- Follow the connection instructions supplied with your amplifier to connect the speaker cables to amplifier. Take care to assign the same cable colour or trace to the positive (+) connector on the amplifier as the positive (+) connector on the speaker.
- Prepare speaker cables for connecting to speakers by neatly stripping cable ends.

⚠ Care should be taken to eliminate loose strands of wire that may be present a short circuit hazard.

installation

- Once the correct placement the speakers has been determined, use the cardboard insert marked 'template' (from the internal packing) to trace the required cut-out onto the ceiling/wall. (figure 5)
- Drill a hole inside the marked cut-out. Using a fine gyprock saw, cut around the inside of the marked cut-out. (figure 6)
- Remove the circular offcut and insert the speaker to check the hole is the correct size. Enlarge the cut-out if required.

⚠ **Atmospherix A20 only:**
Determine the correct orientation for your speaker. A small arrow embossed in the front baffle marks the direction of the speakers primary coverage. It is recommended that this arrow is aimed towards your primary listening area for best results. (Figure 3, Figure 7)

- Pull the stripped speaker cable through the ceiling/wall opening. Push and hold down the positive (+) red binding post on the speaker and insert the positive (+) wire through hole in post. Take care to assign the same cable colour or trace to the positive (+) connector on the amplifier, as the positive (+) connector on the speaker. Repeat connection process with the negative (-) black binding post and the negative (-) wire. (Figure 8)
- Ensure all mounting clamps are swung back against the speaker enclosure (Figure 8), so that the speaker can be easily inserted into the ceiling cut-out. Once the speaker has been located in the ceiling/wall, use a Philips head screwdriver to tighten all mounting screws. As the screws are tightened, the mounting clamps will automatically swing out over the gyprock and clamp the speaker in place. Be careful not to over tighten the screws, as this may strip the clamp, or crush the gyprock surface. (Figure 9)
- Gently fit the magnetic grille to the front of the speaker housing. (Figure 10)

⚠ If the grille requires painting it is recommended that the grille is painted attached to the speaker after installation. Use a small foam roller with a light coverage of thin paint to avoid blocking the holes in the grille.

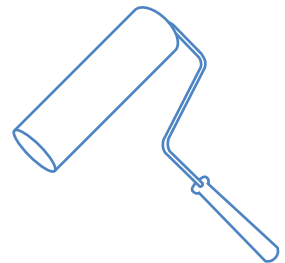

installation

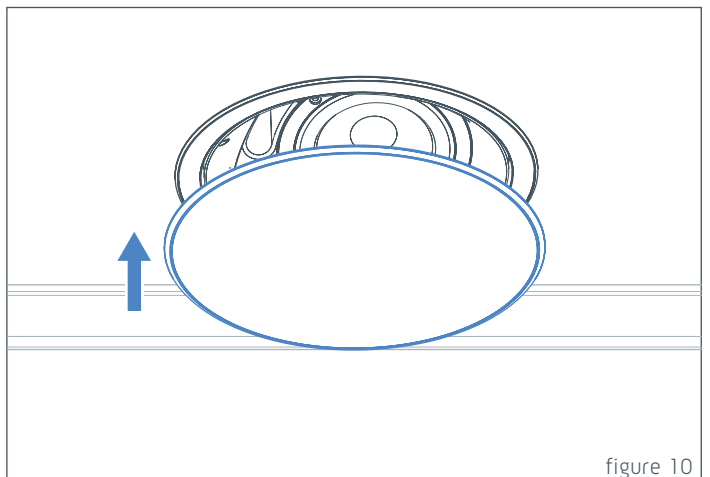
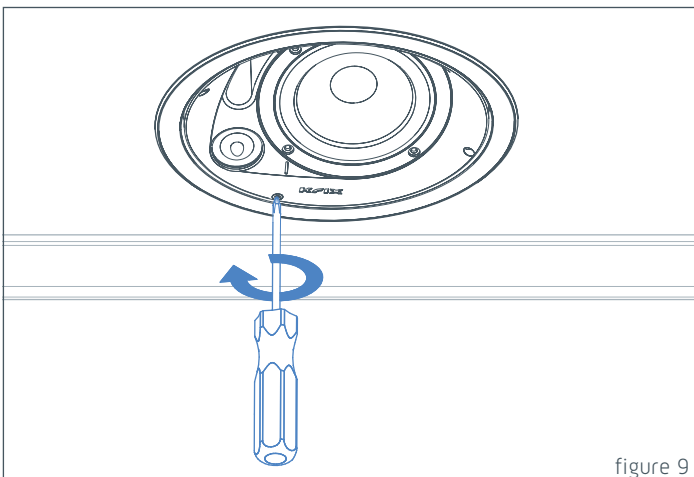
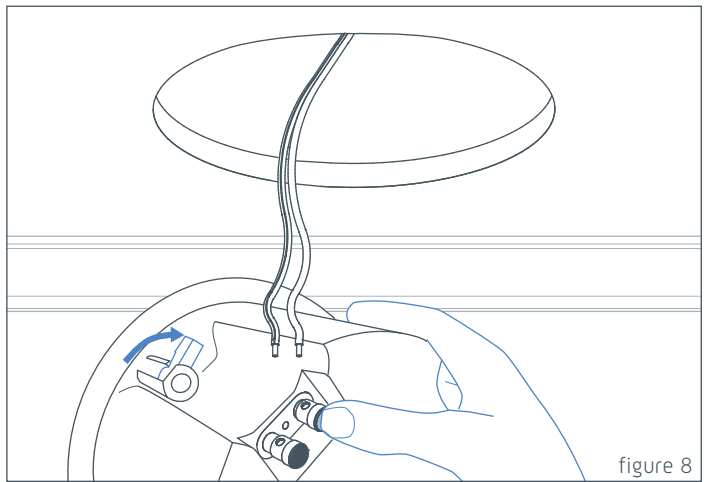
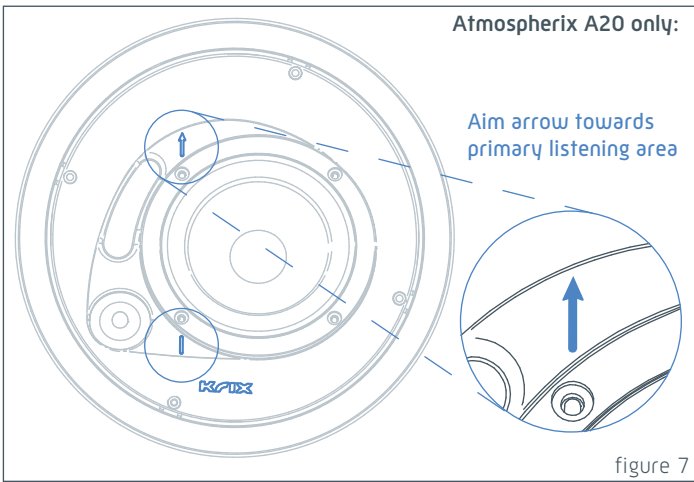
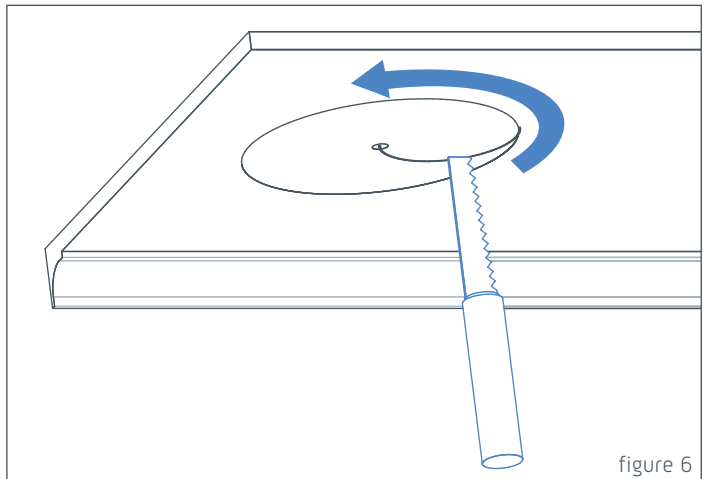
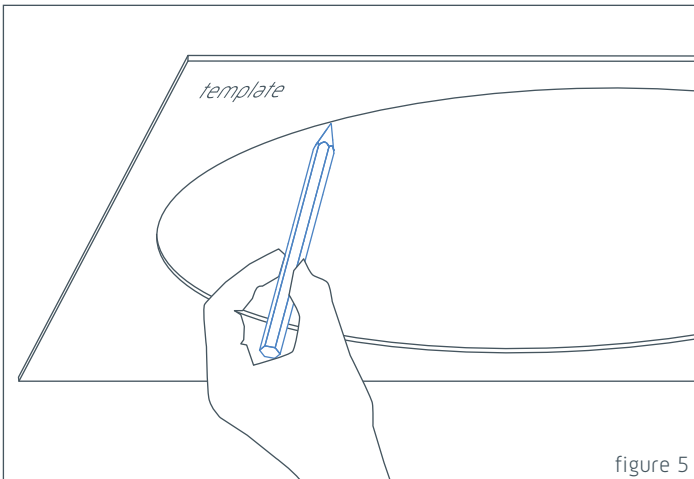

specifications

warranty

5 years warranty applies to the cabinet and speaker.

(Refer to the details on the warranty card supplied)

queries

If you have any queries regarding the Atmospherix or any other Krix product, please contact your nearest Krix dealer or Krix directly. Contact details are on the back cover of this booklet.

Atmospherix AS

Frequency Range	45Hz - 40kHz in room response
Power Handling	20-120 watts RMS recommended amplifier power
Sensitivity	90dB for 2.83 volts at 1 metre
Configuration	5 inch 2-way
Bass Driver(s)	Cast aluminium basket with a nominal 130mm (5") doped curvilinear paper cone. 25mm (1") voice coil wound on high powered aluminium former with copper shorting ring. Vented and double magnet shielded
Tweeter	26mm (1") dual concentric diaphragm with wave-guide centre plug for controlled directivity. Neodymium magnet
Crossover Points	2.1kHz
Impedance	Nominally 8 ohms (minimum 4.9 ohms)
Enclosure Type	Bass reflex, front vented
Dimensions	295mm diameter x 185mm deep
Mounting cut-out diameter	247mm
Finish	White (can be painted to match your décor)
Input Terminals	Push type connectors
Internal Volume	8 litres
Weight	2.5kg each

specifications

Atmospherix A20

Frequency Range	45Hz - 40kHz in room response
Power Handling	20-120 watts RMS recommended amplifier power
Sensitivity	90dB for 2.83 volts at 1 metre
Configuration	5 inch 2-way with 20 degree angle
Bass Driver(s)	Cast aluminium basket with a nominal 130mm (5") doped curvilinear paper cone. 25mm (1") voice coil wound on high powered aluminium former with copper shorting ring. Vented and double magnet shielded
Tweeter	26mm (1") dual concentric diaphragm with wave-guide centre plug for controlled directivity. Neodymium magnet
Crossover Points	2.1kHz
Impedance	Nominally 8 ohms (minimum 4.9 ohms)
Enclosure Type	Bass reflex, front vented
Dimensions	295mm diameter x 195mm deep
Mounting cut-out diameter	247mm
Finish	White (can be painted to match your décor)
Input Terminals	Push type connectors
Internal Volume	8 litres
Weight	2.5kg each

Krix Loudspeakers Pty Ltd
14 Chapman Road
Hackham SA 5163
Australia

T 61 8 8384 3433
F 61 8 8384 3419
listen@krix.com

Rev #10002

krix.com